

# Operation

## Gas rate checking

Instructions for adjusting the PCB and Honeywell gas valve.

Alpha CD boiler range. (Excluding CD13R, CD18R, CD24R)

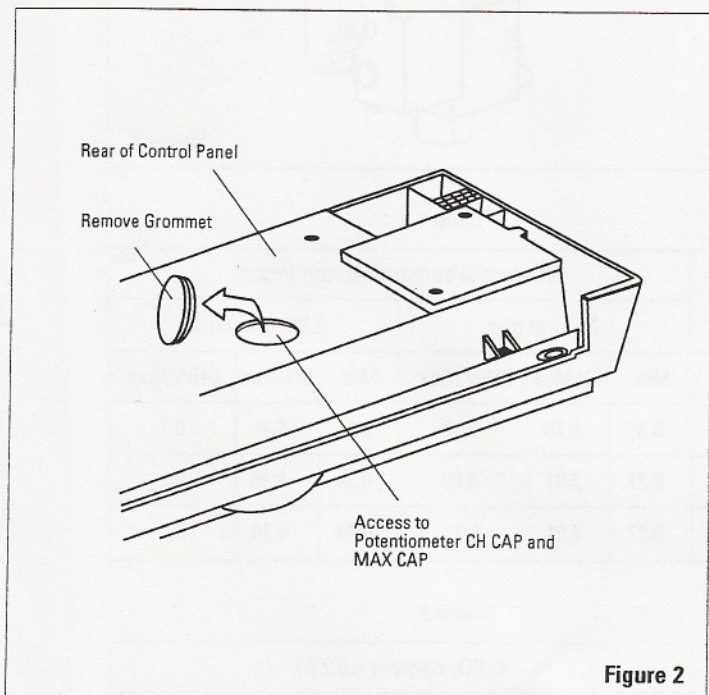
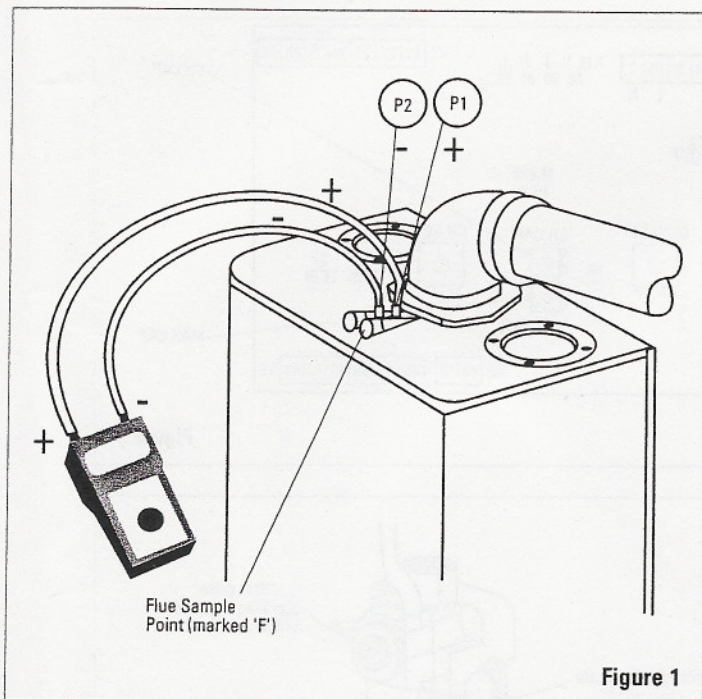

### 1. General

When the printed circuit board (PCB) or Honeywell gas valve have been replaced or require adjustment, the following must be carried out:-

- Check and adjust (if necessary) the CO<sub>2</sub> content of the exhaust flue gases.

**Note:** A flue gas combustion analyser is required for these measurements. Also a 'star drive' screwdriver will be required to adjust the gas valve.

- Check and adjust (if necessary) the burner pressures.

**Note:** A differential pressure gauge will be required to enable the pressure to be correctly set.

- Set the maximum DHW output.

- Set the maximum CH output

- Ensure that all electrical plugs and connectors are pushed fully home and soundly connected.

**Note:** Before fitting a new PCB ensure the polarity of the electrical supply is correct by testing the supply, using a suitable multimeter, as follows:

Live to Neutral	240 Volts AC
Live to Earth	240 Volts AC
Neutral to Earth	zero Volts AC

**Note:** Before fitting the PCB, carefully bend the four neons through 180° so that they locate into the control panel, see Fig. 3.

### 2. Fit the replacement PCB and/or Gas Valve

Refer to the Installation and Servicing instructions to gain access to and replacement of the PCB and/or gas valve.

### 3. Adjust the PCB and Gas Valve to the correct settings

- Remove the screws from the pressure test points P1 and P2 and connect a differential pressure gauge to the test points as shown in Fig. 1. Remove the screw plug and place the flue gas analyser probe into the flue sampling point (marked 'F' on the boiler).

- Remove the grommet in the rear of the control panel (see Fig. 2) to gain access to the PCB. Using a small screwdriver turn the 'CH CAP' potentiometer fully clockwise to maximum output, see Fig. 3.

# Operation

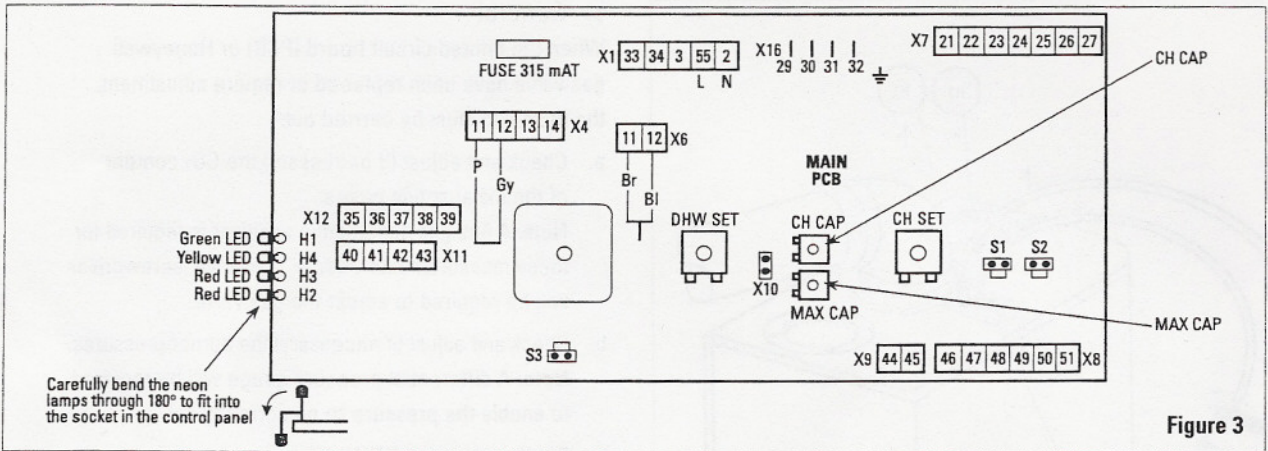

Figure 3

- c. Turn and hold the selector switch to the reset position until the neon 'A' (red) is illuminated. This will operate the boiler at maximum output for 10 minutes.
- d. Allow the boiler to operate for 5 minutes to stabilise, then using a small screwdriver turn the 'MAX CAP' potentiometer (clockwise to increase) until the maximum DHW pressure is obtained on the differential pressure gauge (refer to table 1 for the correct pressure).
- e. Adjust the 'CH CAP' potentiometer by turning screw fully anticlockwise to the minimum output position.
- f. Measure the CO<sub>2</sub> content of the exhaust flue gas at the minimum output with the analyser. If the reading is not within the CO<sub>2</sub> % given in table 2 at the minimum output, then the gas valve must be adjusted.
- g. Using a 'star drive' screwdriver, remove the gas valve blanking cap, see Fig. 4. Turn the inner screw clockwise to increase CO<sub>2</sub> and anticlockwise to reduce CO<sub>2</sub> until the correct value is obtained. Replace the blanking cap.
- h. Adjust the 'CH CAP' potentiometer (clockwise to increase) to give the maximum CH output, i.e. set the burner pressure to the CH Max stated in table 1.
- i. At the maximum outputs check that the CO<sub>2</sub> content of the exhaust flue gas is approximately that given in table 2. If not, repeat the procedure.
- j. Remove the analyser and pressure gauge and re-assemble in the reverse order, ensuring that all the pressure test points and flue sampling points have been refitted with the screws/cap

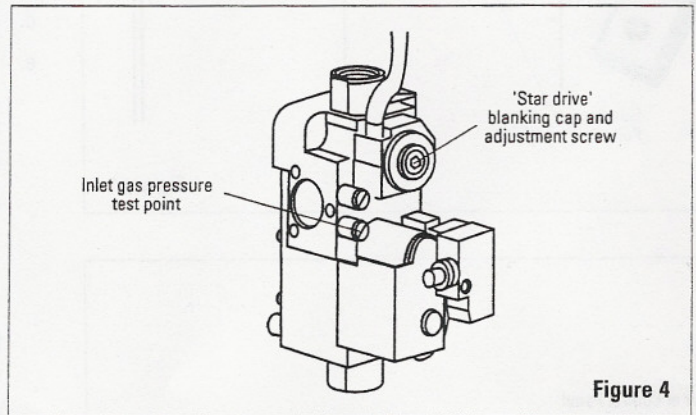

Figure 4

Table 1

Boiler model	Differential burner pressure (mbar)					
	Natural gas			LPG (propane)		
	Min	CH Max	DHW Max	Min	CH Max	DHW Max
CD24	0.35	5.78	5.78	0.4	6.7	6.7
CD32	0.27	2.91	4.09	0.24	4.16	5.9
CD50	0.27	2.91	3.7	0.24	4.16	5.7

Table 2

Boiler model	% CO <sub>2</sub> content (±0.2%)					
	Natural gas			LPG (propane)		
	Min	CH Max	DHW Max	Min	CH Max	DHW Max
CD24	9.0	9.2	9.2	9.7	10.6	10.6
CD32	9.0	9.4	9.5	10.0	10.1	10.2
CD50	9.0	9.4	9.5	10.0	10.1	10.2

# Operation

## Gas rate checking

Instructions for adjusting the PCB and Dungs gas valve.

Alpha CD13R, 18R and 24R boiler range.

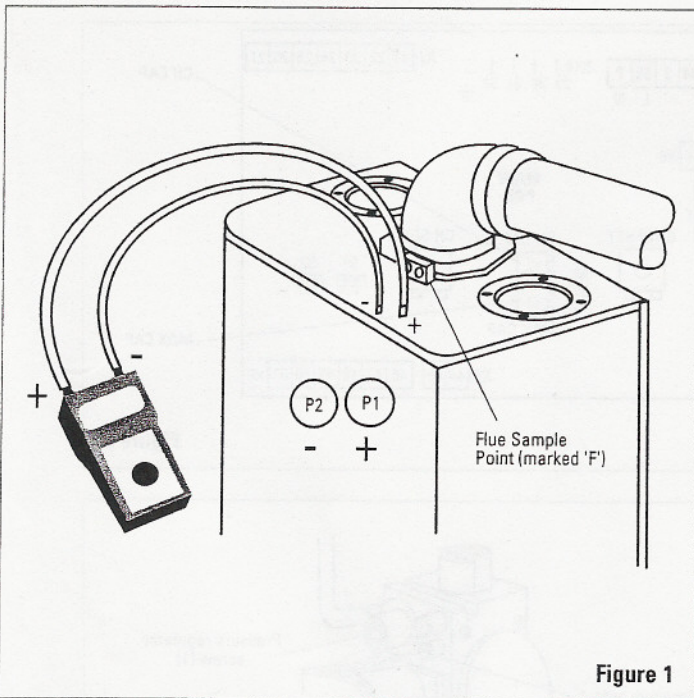

Figure 1

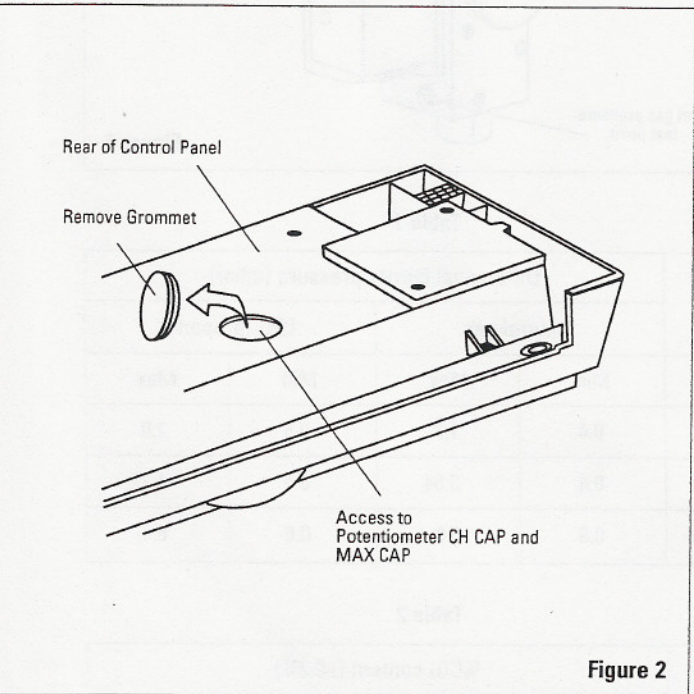

Figure 2

### 1. General

When the printed circuit board (PCB) or Dungs gas valve have been replaced or require adjustment, the following must be carried out:-

- Check and adjust (if necessary) the CO<sub>2</sub> content of the exhaust flue gases.  
**Note:** A flue gas combustion analyser is required for these measurements. Also a 2mm Allen Key will be required to adjust the gas valve.
- Check and adjust (if necessary) the burner pressures.  
**Note:** A differential pressure gauge will be required to enable the pressure to be correctly set.
- Set the maximum output.
- Ensure that all electrical plugs and connectors are pushed fully home and soundly connected.  
**Note:** Before fitting a new PCB ensure the polarity of the electrical supply is correct by testing the supply, using a suitable multimeter, as follows:

Live to Neutral	240 Volts AC
Live to Earth	240 Volts AC
Neutral to Earth	zero Volts AC

**Note:** Before fitting the PCB, carefully bend the four neons through 180° so that they locate into the control panel, see Fig. 3.

- Fit the replacement PCB and/or Gas Valve  
Refer to the Installation and Servicing instructions to gain access to and replacement of the PCB and/or gas valve.

### 3. Adjust the PCB and Gas Valve to the correct settings

- Remove the screws from the pressure test points P1 and P2 and connect a differential pressure gauge to the test points as shown in Fig. 1. Remove the screw plug and place the flue gas analyser probe into the flue sampling point (marked 'F' on the boiler).
- Remove the grommet in the rear of the control panel (see Fig. 2) to gain access to the PCB. Using a small screwdriver turn the 'CH CAP' potentiometer fully clockwise to maximum output, see Fig. 3.
- Turn the selector switch to the reset position until the neon 'A' (red) is illuminated. This will operate the boiler at maximum output for 10 minutes.

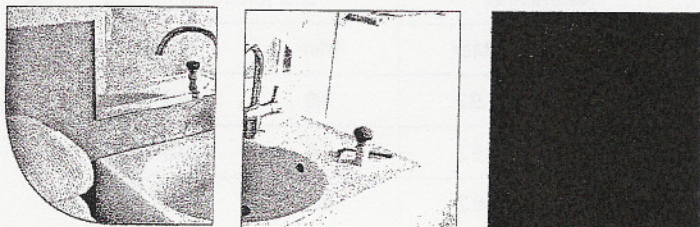

# Operation

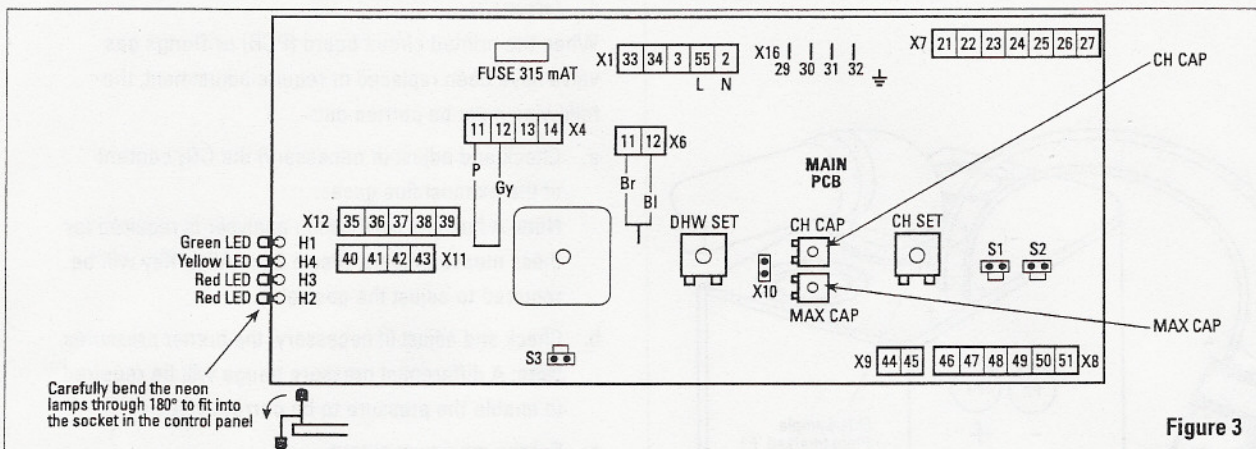

Figure 3

- d. Allow the boiler to operate for 5 minutes to stabilise, then using a small screwdriver turn the 'MAX CAP' potentiometer (clockwise to increase) until the maximum pressure is obtained on the differential pressure gauge (refer to table 1 for the correct pressure).
- e. Adjust the 'CH CAP' potentiometer by turning screw fully anticlockwise to the minimum output position.
- f. Measure the CO<sub>2</sub> content of the exhaust flue gas at the minimum output with the analyser. If the reading is not within the CO<sub>2</sub> % given in table 2 at the minimum output, then the gas valve must be adjusted.

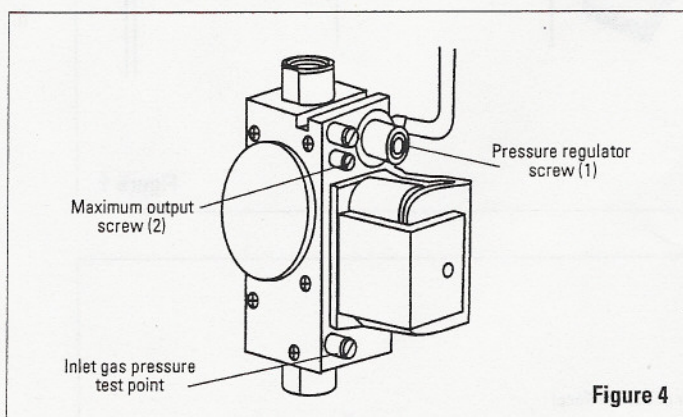

Figure 4

- g. Using an allen key, turn the pressure regulator screw (1), see Fig. 4 clockwise to increase CO<sub>2</sub> and anticlockwise to reduce CO<sub>2</sub> until the correct value given in table 2 is obtained.
- h. Adjust the 'CH CAP' potentiometer to give the maximum CH output (fully clockwise), i.e. set the burner pressure to the Max stated in table 1.
- i. At the maximum outputs check that the CO<sub>2</sub> content of the exhaust flue gas is that stated in table 2. If not, adjust the maximum output screw (2) on the gas valve, see Fig. 4 using a suitable screwdriver until the CO<sub>2</sub> content is correct.\* Then recheck the CO<sub>2</sub> content when the 'CH CAP' potentiometer is at minimum output. Repeat the previous procedures 'e to i' until the correct values are obtained.

Table 1

Boiler model	Differential burner pressure (mbar)			
	Natural gas		LPG (propane)	
	Min	Max	Min	Max
CD13R	0.4	1.7	0.5	2.0
CD18R	0.4	3.54	0.5	4.22
CD24R	0.6	5.6	0.6	6.4

Table 2

Boiler model	%CO <sub>2</sub> content (±0.2%)			
	Natural gas		LPG (propane)	
	Min	Max	Min	Max
CD13R	9.0	9.2	9.8	10.6
CD18R	9.0	9.2	9.8	10.6
CD24R	9.0	9.2	9.8	10.6

**Note:** Ensure the 'CH CAP' potentiometer is set to maximum CH output when adjustment procedure has been completed.

- j. Remove the analyser and pressure gauge and re-assemble in the reverse order, ensuring that all the pressure test points and flue sampling points have been refitted with the screws/cap removed and been tested for soundness.

# Operation

## Gas rate checking

Instructions for setting the burner pressure on a replacement gas valve.

Alpha HE/CB/SY/C boiler range.

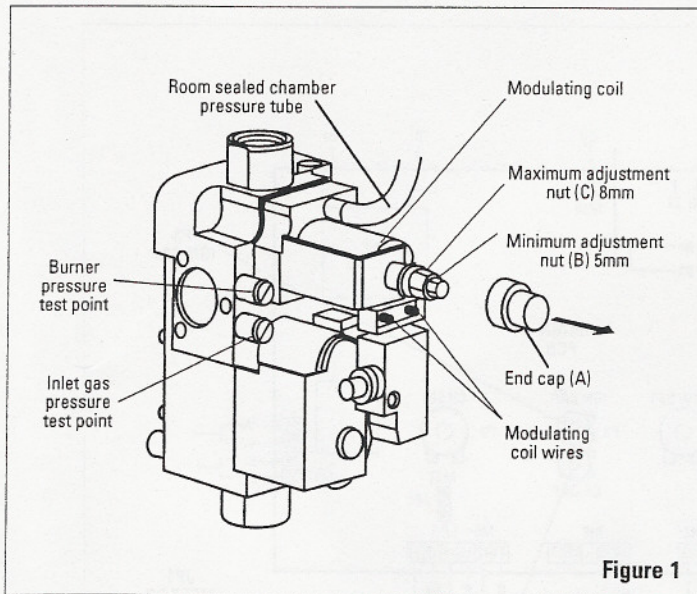

Table 1

Boiler	Maximum Burner Pressure			
	Natural gas		LPG	
	mbar	in w.g.	mbar	in w.g.
HECB25, HESY25	12.3	4.92	32.3	12.92
HECB33	11.6	4.64	32.1	12.84

Table 2

Boiler	Minimum Burner Pressure			
	Natural gas		LPG	
	mbar	in w.g.	mbar	in w.g.
HECB25, HESY25	1.9	0.76	5.6	2.24
HECB33	1.2	0.48	4.7	1.88

### 1. General

The maximum and minimum burner pressures are factory set and should not require adjustment. However, if the gas valve has been replaced, then these burner pressures must be set by adjustment on the gas valve.

Refer to the Installation and Servicing instructions for gaining access to and for replacement of the gas valve.

**Note:** Ensure that the plastic tube between the gas valve and the room sealed chamber is correctly fitted.

### 2. Setting the maximum burner pressure

- Loosen the burner pressure test point on the gas valve (see Fig. 1) and connect a pressure gauge.
  - Remove the end cap (A in Fig. 1) to reveal the two adjustment nuts (B and C in Fig 1).
  - Set the selector switch to  (DHW only) and turn the hot water thermostat to the maximum position.
  - Fully open a hot water tap to give the maximum water flow rate.
  - Using an 8mm spanner, turn the maximum adjustment nut (C in Fig.1) to set the maximum burner pressure (see table below). If the burner fails to light, continue to turn the adjustment nut (C) clockwise until a burner pressure is obtained. During this adjustment the selector switch may have to be turned to 'RESET'. If so, wait 30 seconds each time before resetting.
- Note:** Clockwise to increase the pressure.  
Anticlockwise to decrease the pressure

### 3. Setting the minimum burner pressure

- After the maximum burner pressure has been achieved, the minimum pressure can be adjusted by removing one of the modulating coil (black) wires. The burner pressure will now be at the minimum setting.
  - Using a 5mm spanner, turn the minimum adjustment nut (B in Fig. 1) to set the minimum burner pressure (see table 1).
- Note:** It is advisable to hold the maximum adjustment nut (C) with an 8mm spanner, when adjusting the minimum nut (B).
- Reconnect the modulating coil (black) wire and recheck the maximum pressure. Continue to readjust and recheck until both the maximum and minimum burner pressures are as shown in the table.
  - Disconnect the pressure gauge and tighten the test point screw.
  - Test for gas soundness using a suitable leak detection fluid.

# Operation

HECB25, HECB33 and HESY25

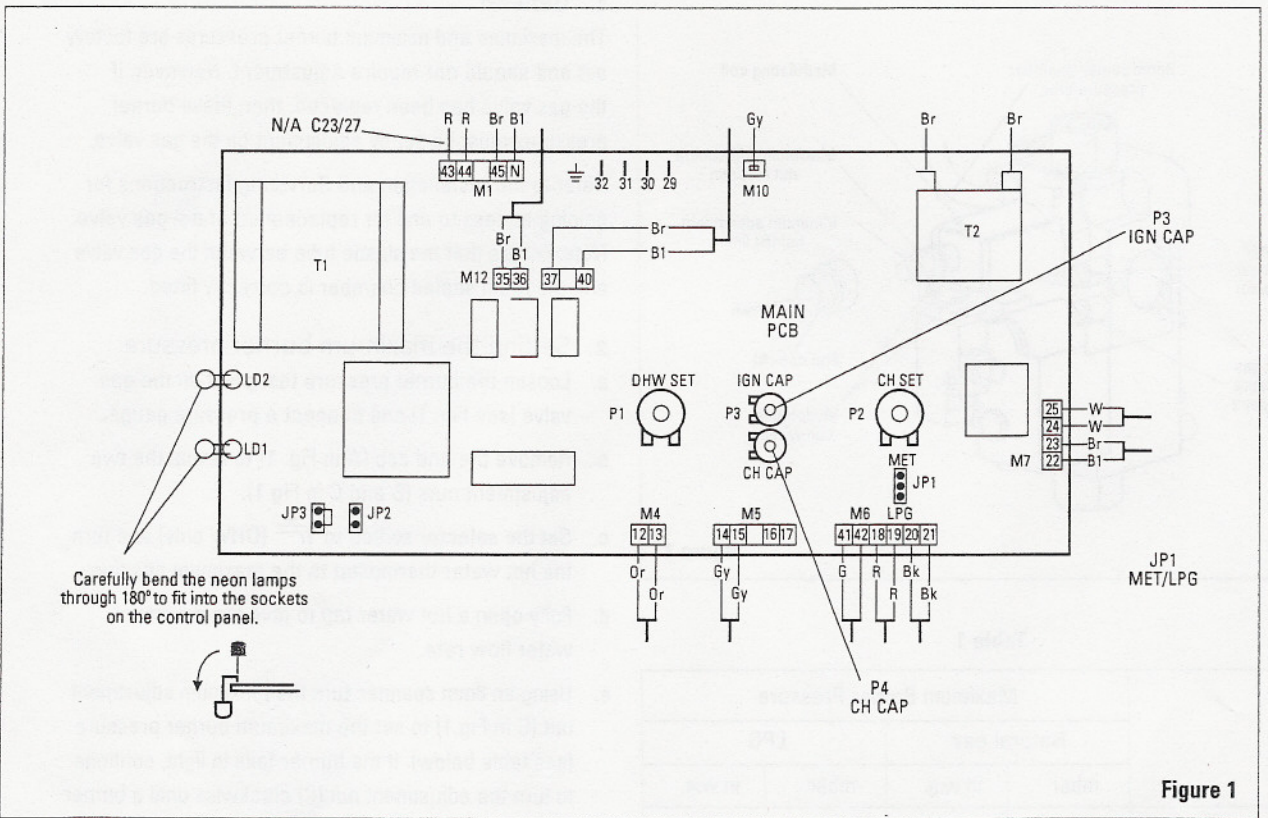

Figure 1

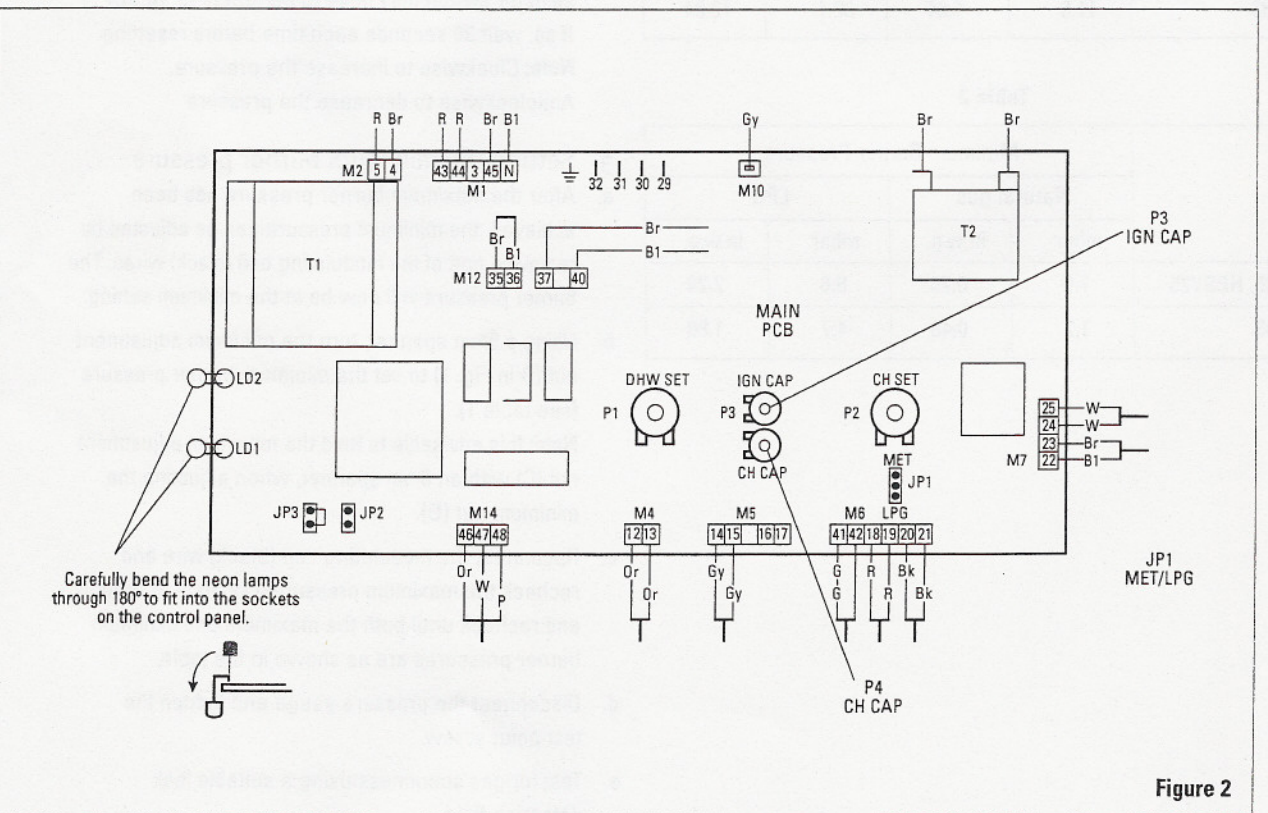

Figure 2

# Operation

## Gas rate checking

### Instructions for adjusting a replacement printed circuit board.

Alpha CB/SY/C boiler range.

#### 1. General

When the Printed Circuit Board (PCB) is replaced the following adjustments **must** be carried out:-

- Set the ignition gas rate so that the ignition of the burner is smooth and quiet.
- Adjust the central heating output.
- Ensure that the JP1 plug is correctly positioned for the type of gas boiler is being used with.

MET – Natural Gas

LPG – Liquefied Petroleum Gas

- Ensure that all electrical plugs and connectors are pushed fully home and soundly connected.

**Note:** Before fitting a new PCB ensure the polarity of the electrical supply is correct by testing the supply, using a suitable multimeter, as follows:-

Live to Neutral 240 Volts AC

Live to Earth 240 Volts AC

Neutral to Earth zero Volts AC

**Note:** (i) Before fitting the PCB, carefully bend the red and yellow neons through 180° so that they locate into the control panel – see Fig. 1 or 2 on page 32.

(ii) When the selector switch is turned to the reset position, there will be a delay of approximately 30 seconds before the PCB will reset.

#### 2. Fit and adjust the replacement PCB

Refer to the Installation and Servicing instructions for gaining access to and for replacement of the PCB. To adjust the PCB the gas valve burner pressures must be measured. Loosen the burner test point screw on the gas valve and connect a pressure gauge. After adjusting the PCB disconnect the pressure gauge, tighten the test point screw and test for gas using a suitable leak detection fluid.

#### Set the Ignition Gas Rate (IGR)

When there is a demand for either Heating or Hot Water, the burner will light at the IGR approximately 5-10 seconds until the flame sensing electrode detects the flame, then the burner pressure will increase to the required output. During the first 5 seconds the IGR pressure must be read on the pressure gauge. If the ignition gas rate is incorrect, adjust the IGR pressure as follows:-

- Set the selector switch to  (DHW only) and turn the hot water thermostat to the maximum position.
- Carefully locate a small insulated screwdriver into the potentiometer P3 (IGN CAP) – see Fig. 1 or 2 on page 32.
- Fully open a hot water tap so that the boiler fires and record the IGR.
- If the IGR is incorrect, rotate the screwdriver (Clockwise to Increase – Anticlockwise to Decrease), to achieve a smooth ignition (see table 1).

- After each adjustment of the potentiometer, repeat the above process from paragraph c.

Adjustment of the Central Heating Output.

The Central Heating Output will normally be set to maximum. If however the system needs to be Range-Rated, adjust the CH output as follows:-

- Set the selector switch to  and the heating thermostat to maximum to operate the boiler on central heating.
- Carefully locate a small insulated screwdriver into the potentiometer P4 (CH CAP) – see Fig. 1 or 2, which should be fully clockwise.
- To Range-Rate the heating output, the potentiometer can be turned anticlockwise to the required output

Fully clockwise	Maximum output
Fully anticlockwise	Minimum output
Half way	Approximately 16.1 kW (55 000 Btu/h) for CB24, CB24X, SY24 & C23
	Approximately 20.5 kW (70 000 Btu/h) for CB28, CB28X, CB50 & C27

Table 1

Boiler	IGR Pressure (Approx.)			
	Natural gas		LPG	
	mbar	in w.g.	mbar	in w.g.
CB24, CB24X, SY24	5.0	2.0	10.0	5.2
CB28, CB28X	5.0	2.0	10.0	5.2
CB50	3.0	1.2	10.0	5.2
C23, C27	5.0	2.0	10.0	5.2